



16573305
Edition 3
December 2009

Air Grinder

88V Series

Parts Information



Save These Instructions

 **Ingersoll Rand**

88V Series Air Grinder Exploded Diagram

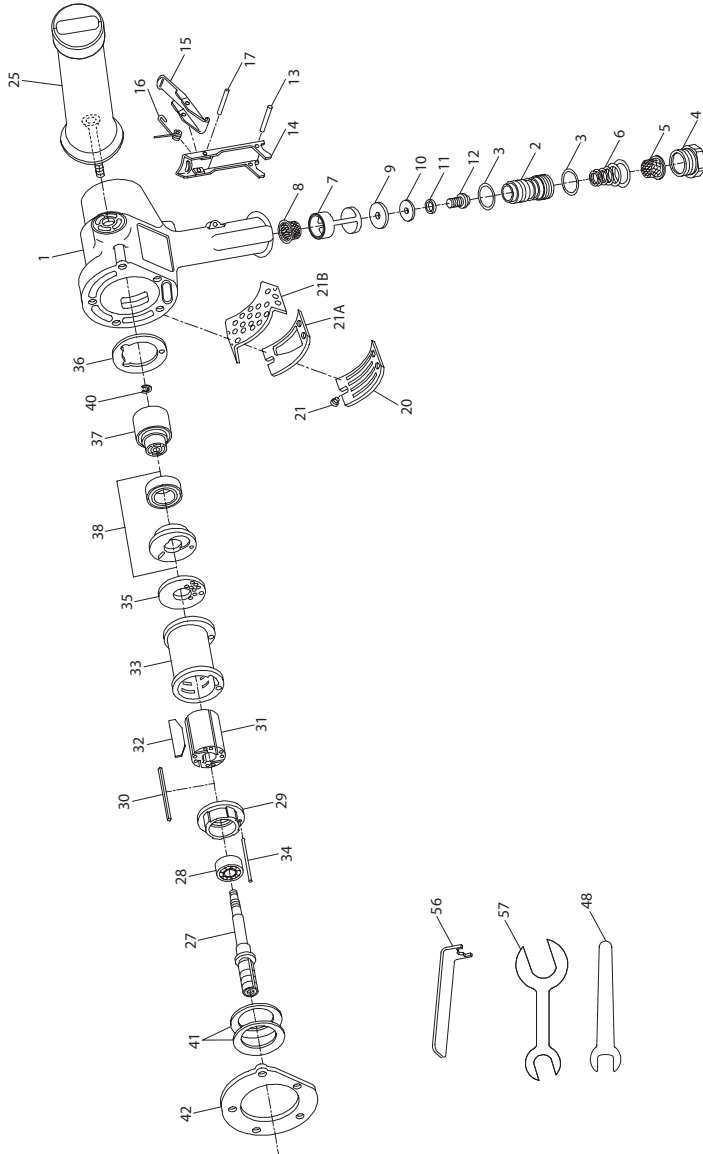

(Dwg. TPA731-4)

88V Series Air Grinder Parts List

Item	Part Description	Part Number	Item	Part Description	Part Number
† 1	Cylinder Case Assembly		21A	Exhaust Deflector (for 88V60-EU, 88V77 and 88V85)	88V77-123
	for models ending in -EU	88V60-EU-A25			
	for all other models	88V60-A25	21B	Exhaust Baffle (for 88V60-EU, 88V77 and 88V85)	88V77-311
2	Throttle Valve Assembly	88V60-A302			
† • 3	Seal (2)	C321-606	25	Dead Handle	88V60-48
4	Inlet Bushing	88V60-38	27	Arbor	
† • 5	Inlet Bushing Screen	834-61		for 88V60 (Blue)	88V60-204-P10
† • 6	Throttle Valve Spring	99V60-262		for 88V77 (Green)	88V77-204-P10
7	Throttle Valve Seat Support Assembly	88V60-A303		for 88V85 (Red)	88V85-204-P10
† • 8	Air Strainer Screen	834-61	28	Front Rotor Bearing	R380-105
† • 9	Valve Seat	R4-159A	29	Front End Plate	88V60-11
10	Valve Seat Washer	99V60-155	• 30	Rotor Key	88V60-70
11	Valve Screw Lock Washer	H54U-352	31	Rotor	88V60-53
12	Valve Seat Screw	PS3-83	† • 32	Vane Packet (set of 4 Vanes)	88V60-42-4
• 13	Throttle Lever Pin	MR-100	33	Cylinder	88V60-3
14	Locking Lever Assembly	88V60-A400	• 34	Cylinder Dowel	88V60-98
15	Lever Lock	88V60-402	35	Rear End Plate	88V60-12
16	Lever Lock Spring	88V60-405	† • 36	Rear End Plate Gasket	88V60-739
17	Lever Lock Pin	502B-120	37	Controller Assembly	
*	Nameplate Kit (for 88V60-EU-A25)	88V-EU-K301		for 88V60 (6000 rpm) (Blue)	88V60-A524
*	Nameplate Screw (for 88V60-EU-A25) (4)	BN403-302		for 88V77 (7700 rpm) (Green)	88V77-A524
*	Warning Label (for 88V60-EU-A25)	EU-99		for 88V85 (8500 rpm) (Red)	88V85-A524
*	Nameplate Kit (for 88V60-A25)	88V-K301	38	Rotor Bearing Seal Assembly	88V60-A28
	Nameplate Screw (4)	BN403-302	† 40	Controller Retaining Ring	88V60-118
	Warning Label	WARNING-2-99	41	Motor Clamp Belleville Washer (2)	88V60-207
20	Exhaust Deflector	99V60-23	† • 42	Cylinder Case Gasket	88V60-283
21	Exhaust Deflector Screw (3)	99V60-200			

* Not Illustrated.

• To keep downtime to a minimum, it is desirable to have on hand certain repair parts. We recommend that you stock one (pair or set) of each part indicated by a bullet (•) for every four tools in service.

† Whenever a new Cylinder Case Assembly is installed, select the correct Nameplate from the Nameplate Kit and attach it to the Cylinder Case with the Nameplate Screws.

† Indicates Tune-up Kit part.

88V Series Air Grinder Guards, Flanges and Spacers Exploded Diagram

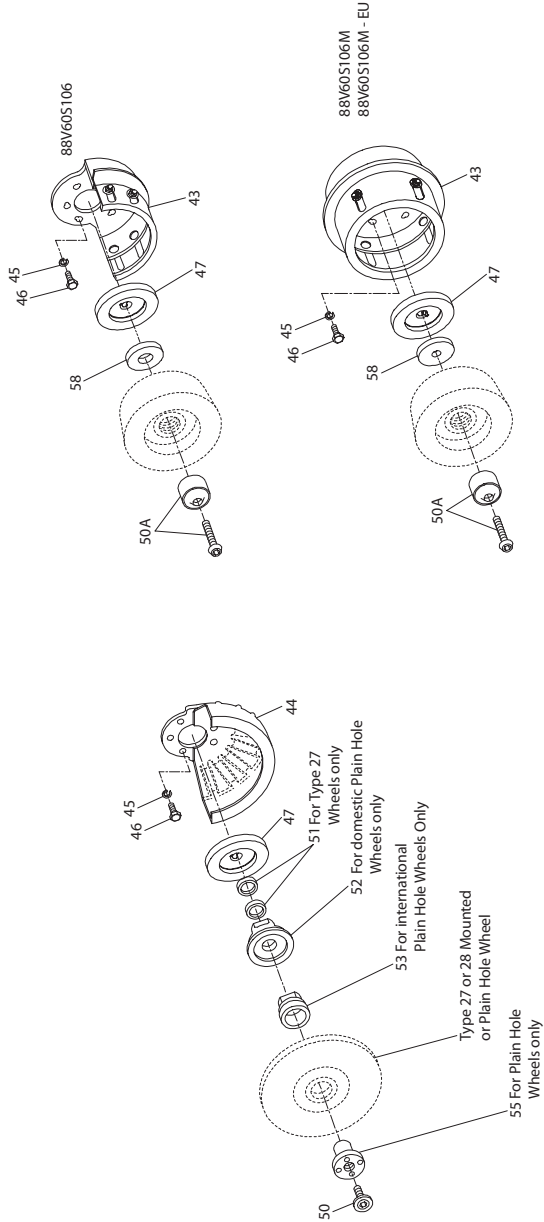

(Dwg. TPA732-3)

88V Series Air Grinder Guards, Flanges and Spacers Parts List

Item	Part Description	Part Number	Item	Part Description	Part Number
43	Cup Wheel Guard		55	Depressed Center Wheel Nut (for Plain Hole Wheels)	99V85-186
	for 88V60S106	88V60-A216			
	for 88V60S106M	88V60-A216M	56	Depressed Center Wheel Nut Spanner Wrench	D32-26
44	Depressed Center Wheel Guard (for Type 27 or 28 Wheels)		57	Disc Wheel Flange Wrench (for 88V60P107M, 88V60P109M, 88V77107M and 88V85P107M)	7RAQT4-254
		for 88V60P109 and 88V60P109M	88V60-106-9	58	Wheel Flange (for 88V60S106, 88V60S106M and 88V60S106M-EU)
	for 88V60P107, 88V60P107M, 88V77P107, 88V77P107M and 88V85P107M	88V60-106-7	*		
			*	Exhaust Hose	99V60-184
			*	Exhaust Hose Clamp	DG30-67
45	Cylinder Case Screw Lock Washer (5)	10BM-67	*	Exhaust Elbow	88V60-167
46	Cylinder Case Screw (5)	99V60-638	*	Exhaust Elbow Gasket	99V60-49
47	Autobalancer Assembly	99V60-A713	*	Exhaust Elbow Screw (3)	FEA100-112
48	Autobalancer Wrench	88V60-169	*	Exhaust Hose Band Assembly	99V60-A927
50	Wheel Retaining Screw (for Type 27 and Type 28 Mounted Wheels and Type 28 Plain Hole Wheels)	99V60-219	*	Cap Screw (2)	JC3350-103
			*	Nut (6)	G8-120A
			*	Exhaust Hose Band (4)	99V60-927
50A	Wheel Retaining Screw Assembly (for Type 6 or Type 11 Cup Wheels)	99V60-A219C	*	Screw (4)	MT1-36-7/8
*	Wheel Retaining Screw Wrench	88V-562	*	Tool Kit	88V60-K950
51	Depressed Center Wheel Spacer (for Type 27 Plain Hole Wheels) (2)	99V-286	*	Controller Wrench	88V60-950
			*	Seal Pressing Tool	99V60-951
52	Depressed Center Wheel Flange (for 7" and 9" diameter Type 27 and Type 28 Plain Hole Wheels)	99V60-386	*	Bearing Clamp Assembly	99V60-A952
			*	Deflector Screw Wrench	R2J-562
53	Depressed Center Wheel Flange Assembly (for 180 mm and 230 mm diameter Type 27 Plain Hole Depressed Center Wheels)	99V60-386-M	*	Tune-up Kit (includes illustrated parts: 3 [2], 5, 6, 9, 32, 36, 40 and 42)	88V/88H-TK3

* Not Illustrated.

Parts and Maintenance

When the life of the tool has expired, it is recommended that the tool be disassembled, degreased and parts be separated by material so that they can be recycled.

Tool repair and maintenance should only be carried out by an authorized Service Center.

Refer all communications to the nearest **Ingersoll Rand** Office or Distributor.

Related Documentation

For additional information refer to:

Product Safety Information Manual 04584959.

Product Information Manuals 16573222 and 16576092.

Maintenance Information Manual 16573362.

Manuals can be downloaded from www.ingersollrandproducts.com.

Notes:

Notes:

www.ingersollrandproducts.com

© 2009 **Ingersoll Rand** Company

